

# SkyAzúl

EQUIPMENT SOLUTIONS

## HOIST DRUM ROTATION INDICATOR



INSTALLATION MANUAL



---

## NOTICE

SkyAzúl makes no warranty of any kind with regard to this material, including, but not limited to, the implied warranties of merchantability and/or its fitness for a particular purpose.

SkyAzúl will not be liable for errors contained in this manual or for incidental or consequential damages in connection with the furnishing, performance, or use of this manual. This document contains proprietary information, which is protected by copyright, and all rights are reserved.

No part of this document may be photocopied, reproduced, or translated to another language without the prior written consent of SkyAzúl.

SkyAzúl reserves proprietary rights to all drawings, photos and the data contained therein. The drawings, photos and data are confidential and cannot be used or reproduced without the written consent of SkyAzúl. The drawings and/or photos are subject to technical modification without prior notice.

All information in this document is subject to change without notice.



**SkyAzúl, Inc.**  
200 W. Main Street, Suite, 2A  
Middletown, MD 21769  
Fax 301-371-0029  
[info@skyazul.com](mailto:info@skyazul.com)



**HDR™ K240260**  
**HOIST DRUM ROTATION INDICATOR KIT**

---

**TABLE OF CONTENTS**

OPERATIONAL FEATURES..... 3

SPECIFICATIONS ..... 4

INSTALLING THE HDR™ TRANSMITTER  
A240260 ..... 5

INSTALLING THE HDR™ DRIVER  
A240240 (12 volt)  
A240241 (24 volt) ..... 6

INSTALLING THE HDR™ INDICATOR  
A240230 ..... 7



# HDR™ K240260 HOIST DRUM ROTATION INDICATOR KIT

The Hoist Drum Rotation Indicator Kit includes three basic components: a TRANSMITTER, a DRIVER, and an INDICATOR.

## OPERATIONAL FEATURES

- **FAST INDICATION:** Operator “feels” the direct Drum response which assists in controlling the operation of the lever.
- **HIGH TORQUE:** Provides accurate and stable indications even at a very slow speed.
- **BI-DIRECTIONAL:** Follows and displays the direction of the drum rotation (clockwise or counterclockwise) with equal precision and torque.
- **LONG LIFE:** Allows long, reliable operation with a minimum of moving parts, friction, and wear.
- **EASY INSTALLATION:** Uses existing mounting hardware and levers. (Universal hardware is available.)

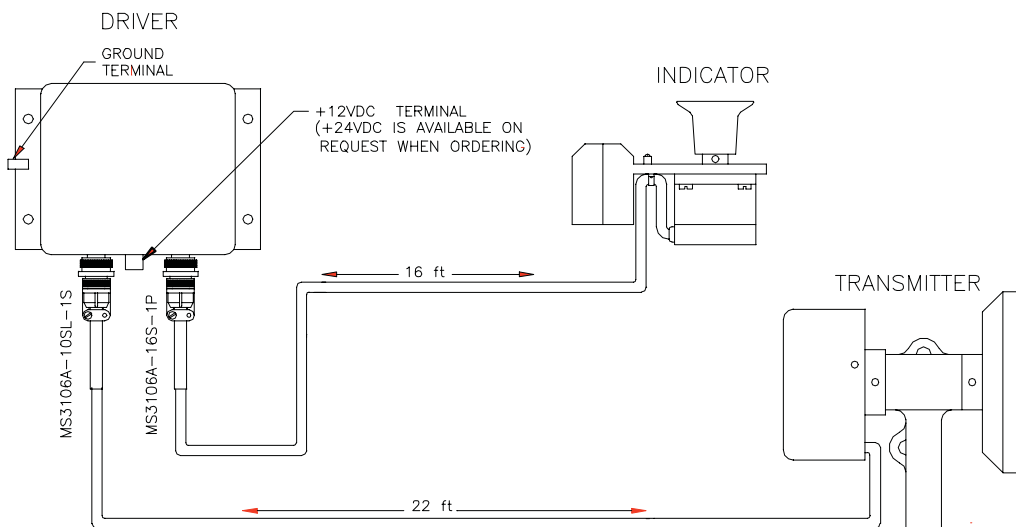

**FIGURE 1: SYSTEM CABLING**

---

## **SPECIFICATIONS**

### **TRANSMITTER – A240260**

- Bi-directional sensing, pulse generator, coupled to the drum by a 5" rubber wheel
- Housed in a 3"x 3" x 2" box
- Wire cable for driver interconnection

### **DRIVER – A240240 (12 volts) or A240241 (24 volts)**

- Solid state electronic translator and power driver
- Housed in a 5" x 5" x 4" box
- Two-wire 12 or 24 volt battery input connection (voltage must be specified)

### **INDICATOR – A240230**

- Electrical step motor with clamp attachment provides lever control
- Output to a "toothed" indicator rubber cup
- Housing 2" x 2" x 3" with an overall length of 6"
- Wire cable for driver interconnection
- Can be used in dual operator station, such as boom trucks with second indicator + splitter cable available upon request.

### **POWER**

- 12 VDC, 5 amps/24VDC

### **SPEED**

- 0 to 200 RPM continuous  
(Indicator may be stalled for any period without loss of operation or tactile feel)

### **REMOTE DISTANCE**

Up to 200 ft. – Extension cable available upon request.

### **OPERATING TEMPERATURE**

– 40 °F to + 130 °F

## INSTALLING THE HDR™ TRANSMITTER

1. Mount the transmitter on the hoist drum frame so that the wheel rolls along the top of the drum flange.

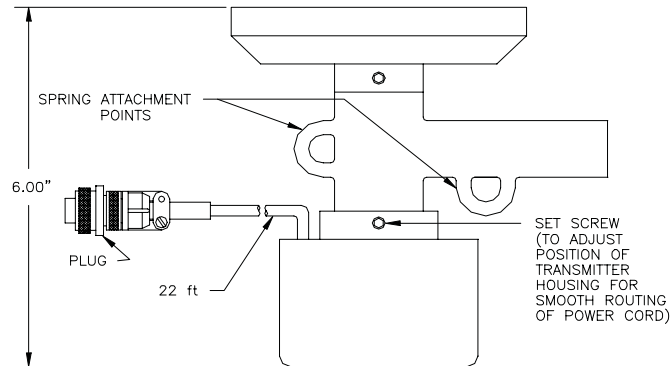

**Note:** If the transmitter cable is routed through the slip rings, the wire colors must be matched on each side. Green must go to green, black to black, and white to white.

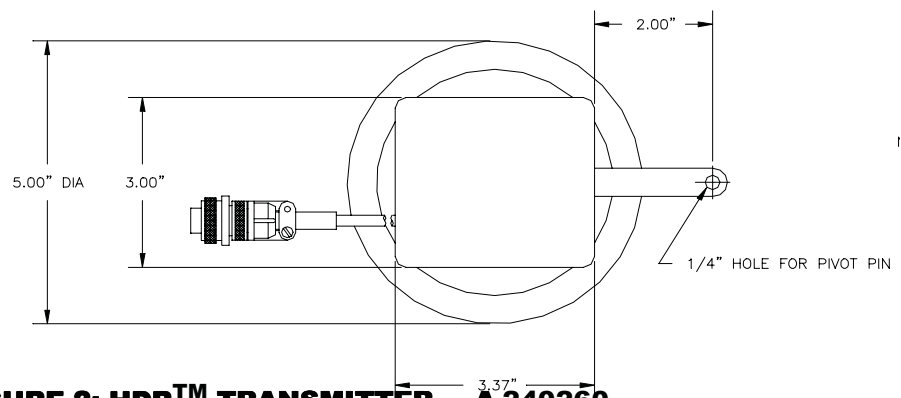

**FIGURE 2: HDR™ TRANSMITTER – A 240260**

### Universal Mounting Hardware:

Transmitter Part Numbers

Spring: P065015

Bracket: P065016

cause the wheel to bounce when the drum rotates rapidly. Remove all such irregularities before installing the transmitter.

**Note:** Do not extend the wheel over the drum to prevent the wire rope from snagging or rubbing on the drum.

3. Loosen the set screw in the base near the cord and rotate the transmitter case for best routing of the power cable.
  - Route the cable so that any boom movement does not wear, abrade, or impose undue tension on the cable. **Note:** Keep the cable clear of areas that might cause abrasion, wear, or damage. Do **not** pinch or crush the cable.
  - Clamp the cable, as necessary, to the frame to prevent pinching or snagging.
  - Route the cable to the driver.
  - Align the keyways before inserting the plug in the driver receptacle.
  - Tighten the threaded retaining collar finger tight.

## INSTALLING THE HDR™ DRIVER

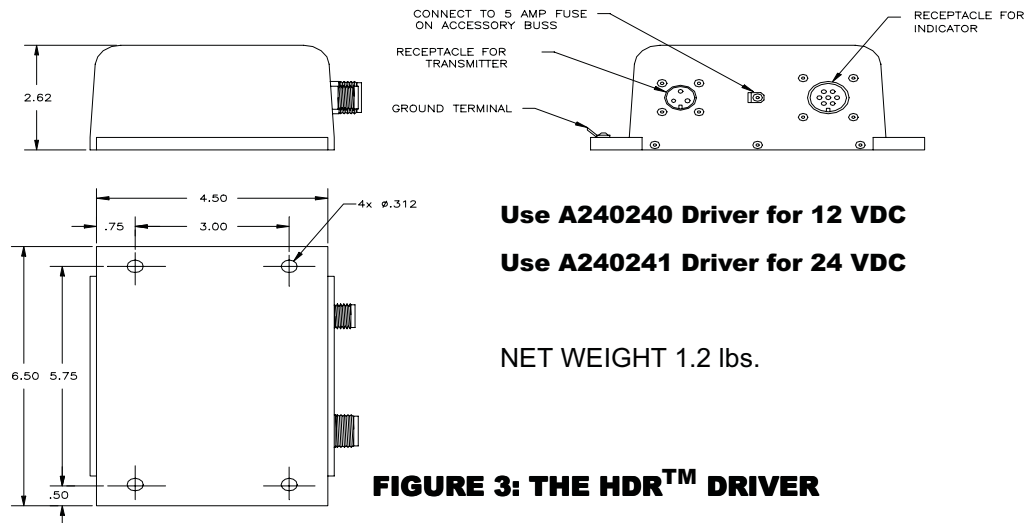

**FIGURE 3: THE HDR™ DRIVER**

1. Mount the driver amplifier unit with four (4) 1/4" bolts in the hydraulic compartment or in an area where the unit will **never** be exposed to direct moisture or rain. Position the unit so that the plugs from the transmitter and indicator units can be easily installed after the unit is mounted.
2. Connect a No. 14 AWG electrical wire from the ground terminal to a clean ground on the cab or frame. Connect **another** No. 14 AWG insulated electrical wire from the terminal between the receptacles to a fused terminal post that is turned "on and off" by the ignition switch. The fuse should not be larger than five (5) amps.

**Note:** If a fused terminal is not available, use an in-line fuse and connect to any terminal post which is turned on and off by the ignition switch. If the unit is connected to a terminal that is not turned off, the battery will run down.

3. After the indicator and transmitter are mounted, connect the plugs from these devices to the driver.

**Note:** Be sure to align the keyways in the plugs and receptacles before inserting and tightening the threaded collars finger tight.

## INSTALLING THE HDR™ INDICATOR

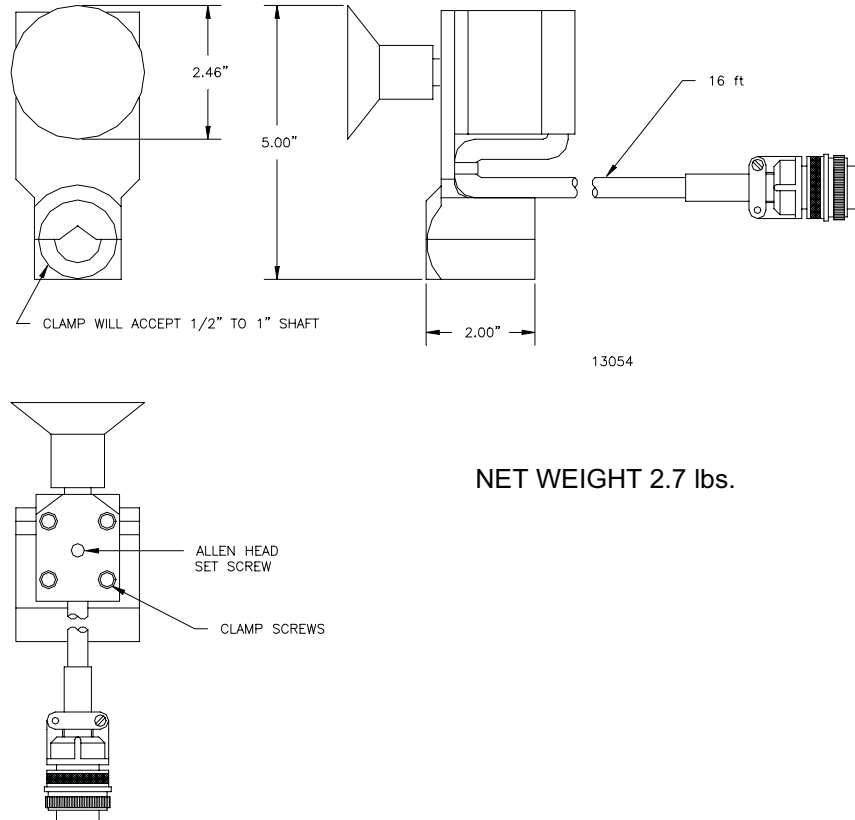

**FIGURE 4: HDR™ INDICATOR A240230**

1. Mount the indicator on the hoist control lever using the set screw to lock it in position after the four (4) clamp screws have been tightened.
2. Route the cable down the lever, along the cab wall, and back to the driver amplifier. Clamp into place using plastic ties.  
**(Note: Keep the cable clear of areas that might cause abrasion, wear, or damage. Do not pinch or crush the cable.)**
3. Connect the cable plug to the seven (7) pin transmitter receptacles. Be sure to align the keyways before inserting and tightening the threaded retaining collar finger.







[www.skyazul.com](http://www.skyazul.com)

**SkyAzul, Inc.**

200 W. Main Street, Suite, 2A  
Middletown, MD 21769  
Phone 301-371-6126  
Fax 301-371-0029  
[info@skyazul.com](mailto:info@skyazul.com)

