

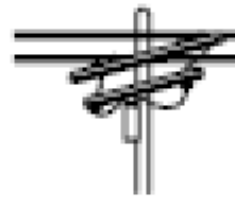

## SIGALARM MODEL 210

HIGH VOLTAGE POWER LINE  
PROXIMITY WARNING SYSTEM



INSTALLATION AND OPERATOR'S MANUAL





**NOTICE:**

**SIGALARM IS INTENDED TO BE AN AID TO YOU IN THE AVOIDANCE OF POWER LINE CONTACT TYPE ACCIDENTS. OBEY ALL LAWS, REGULATIONS, AND COMPANY REQUIREMENTS AND MOST IMPORTANTLY, USE COMMON SENSE.**

**SIGALARM IS NOT INTENDED TO REPLACE ANY OF THESE OTHER SAFETY FACTORS, IT IS THERE TO PROVIDE AN ADDITIONAL SAFETY TOOL BUT YOU HAVE TO USE IT PROPERLY IF IT IS TO BE OF ANY VALUE.**

**IF ANY PROBLEM CANNOT BE RESOLVED, PLEASE WRITE OR CALL AND DESCRIBE THE TROUBLE. DO NOT SHIP WITHOUT PRIOR AUTHORIZATION.**

REV	DATE	NAME	DESCRIPTION
-	06/17/08	SC	MODEL 210 INSTALLATION AND OPERATOR'S MANUAL
A	01/02/09	SC	ADDITION OF REEL, CABLE GUIDE, AND BRACKET INSTALLATION, INTRODUCTION AND FAMILIARIZATION



**SkyAzul, Inc.**  
200 W. Main Street, Suite, 2A  
Middletown, MD 21769  
Fax 301-371-0029  
[info@skyazul.com](mailto:info@skyazul.com)



**TABLE OF CONTENTS**

**1 ELECTROSTATIC FIELD DETECTION SYSTEM ..... 7**

**2 PIGTAIL DIAGRAM ..... 8**

**3 INSTALLATION ..... 9**

**4 INTERNAL CABLE REEL DIAGRAM ..... 10**

**5 MOUNTING OF THE REEL, CABLE GUIDES, AND BRACKETS ..... 11**

**6 ANTENNA INSTALLATION ..... 15**

**7 TESTING ..... 16**

**8 TROUBLESHOOTING TIPS ..... 16**

**9 SPECIAL NOTES ..... 17**

**10 SPECIFICATIONS: ..... 18**

**OPERATION ..... 19**

**11 OPERATIONAL INTRODUCTION ..... 19**

    11.1 GENERAL DESCRIPTION ..... 19

    11.2 THEORY OF OPERATION ..... 19

**12 FRONT PANEL FAMILIARITY: ..... 20**

**13 OPERATING PROCEDURES: ..... 22**

    13.1 OPERATION ..... 22

**14 COMMON QUESTIONS CONCERNING VOLTAGE/GROUNDING: ..... 25**



## 1 ELECTROSTATIC FIELD DETECTION SYSTEM

**Background:** Sigalarm antenna system is designed to protect the entire mast and has a test system designed in the control box to test the entire system including the antenna and the electronics control system. This is accomplished by pushing and holding the test button on the control box for approximately three seconds, this action applies 12 volts dc to the antenna which checks out the entire antenna to insure that there are no breaks. Understanding the above makes it easier when installing the antenna system. "Note" Antenna leads use a minimum of 22 gauge wire this is a very low current application. (Less than 2 ma for however long the test button is held).

**The following wiring options may be utilized to connect antenna lead in with antenna pigtail:**

**(A)** Sigalarm will supply the entire antenna system models: 110,210, 310, and 510

**(B)** Inspect for any existing spare wires that may exist. This includes coaxial cables, single or double wire shielded cables, or two single unshielded cables.

**(1)** If a single coaxial cable is utilized the shield may be utilized as one of the two leads that is required in order to test the antenna system. Shield must go to black wire of antenna lead in.

**(2)** If a single wire shielded cable or two wire coaxial is utilized the shield may be utilized as one of the two wire that is required to test the antenna system. The shield provides an excellent electrostatic field detector. Shield must go to black wire of antenna lead in.

**(3)** If a double wire shielded cable is utilized the shield must be utilized as one of the two wires that is required to test the system (note) if the two center wires are used one of wires must be connected to the shield where it connects to the pigtails at the top of the mast. Shield must go to black wire of antenna lead in.

**(4)** If two unshielded wires are available they may be utilized and can be installed as a standard hookup.

**If AC is used anywhere on vehicle, the Sigalarm unit might detect this field and alarm depending on the set sensitivity. If this happens, it is recommended to use a shielded antenna wire near AC power. Please note that now the "active" part of the antenna is only the non shielded portion and not the entire length of antenna.**

## 2 PIGTAIL DIAGRAM

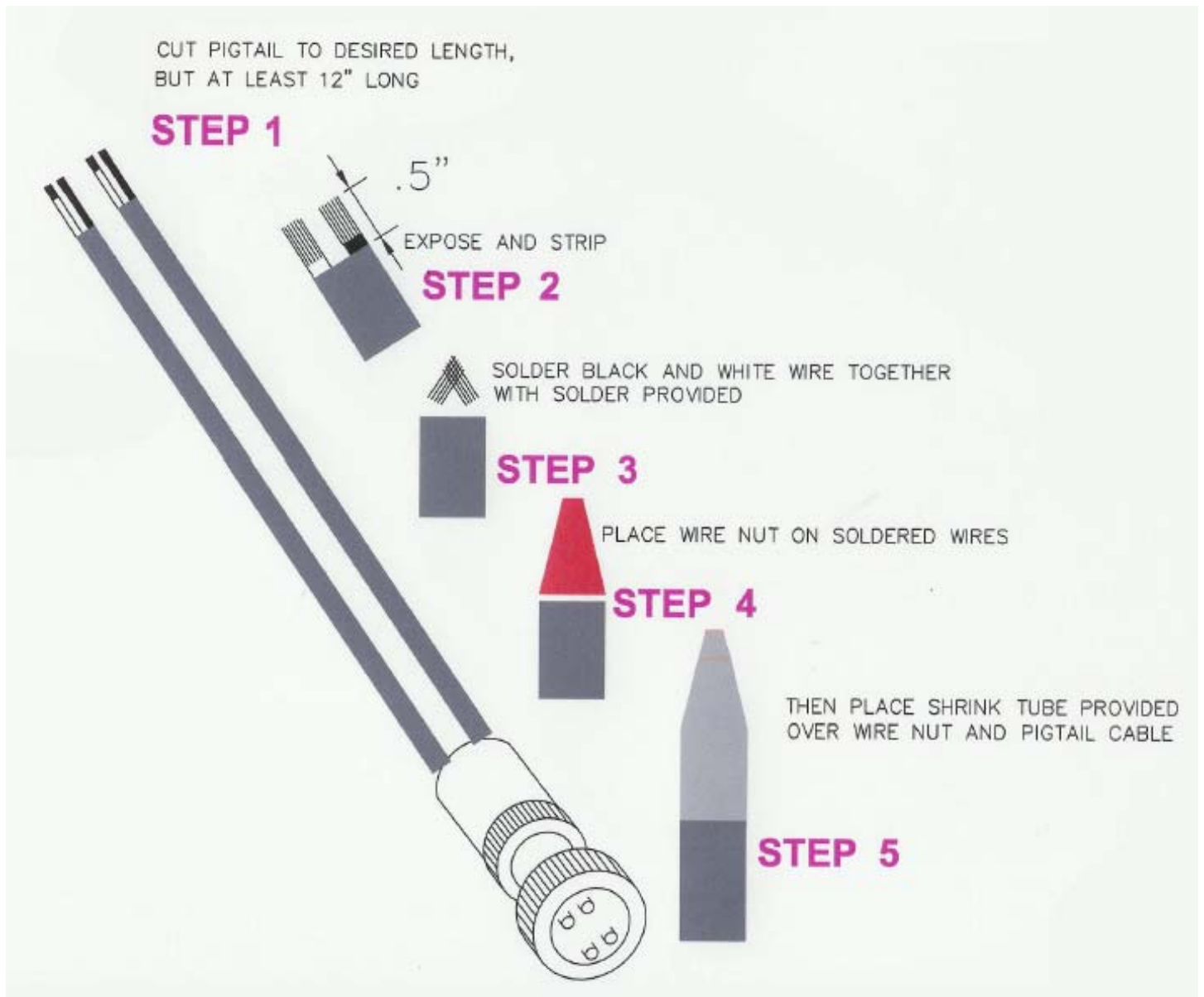

### 3 INSTALLATION

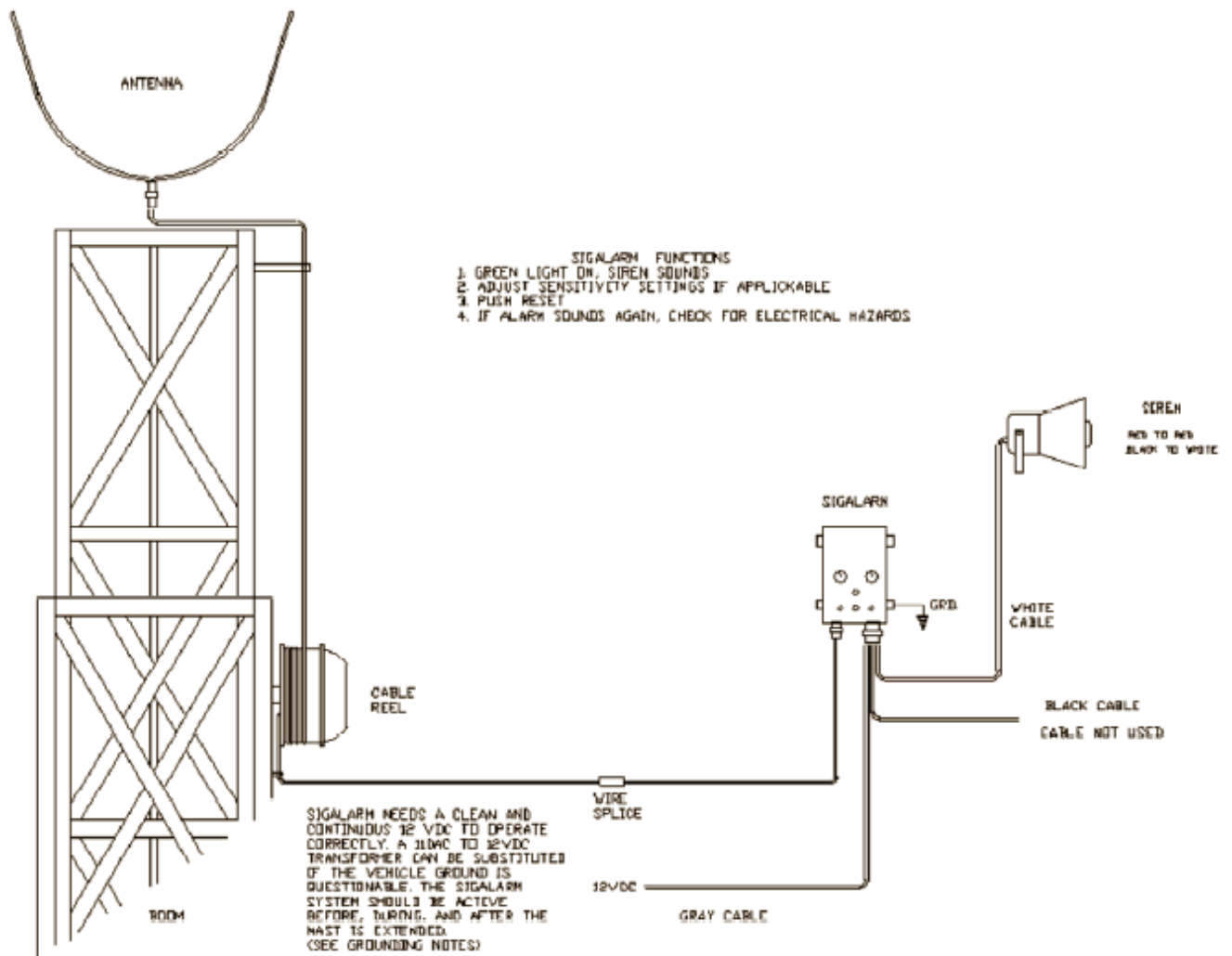

### 4 INTERNAL CABLE REEL DIAGRAM

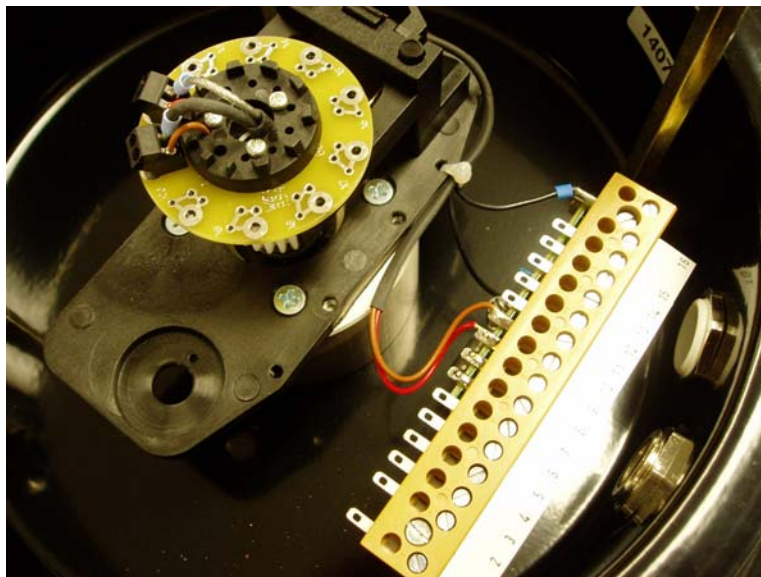
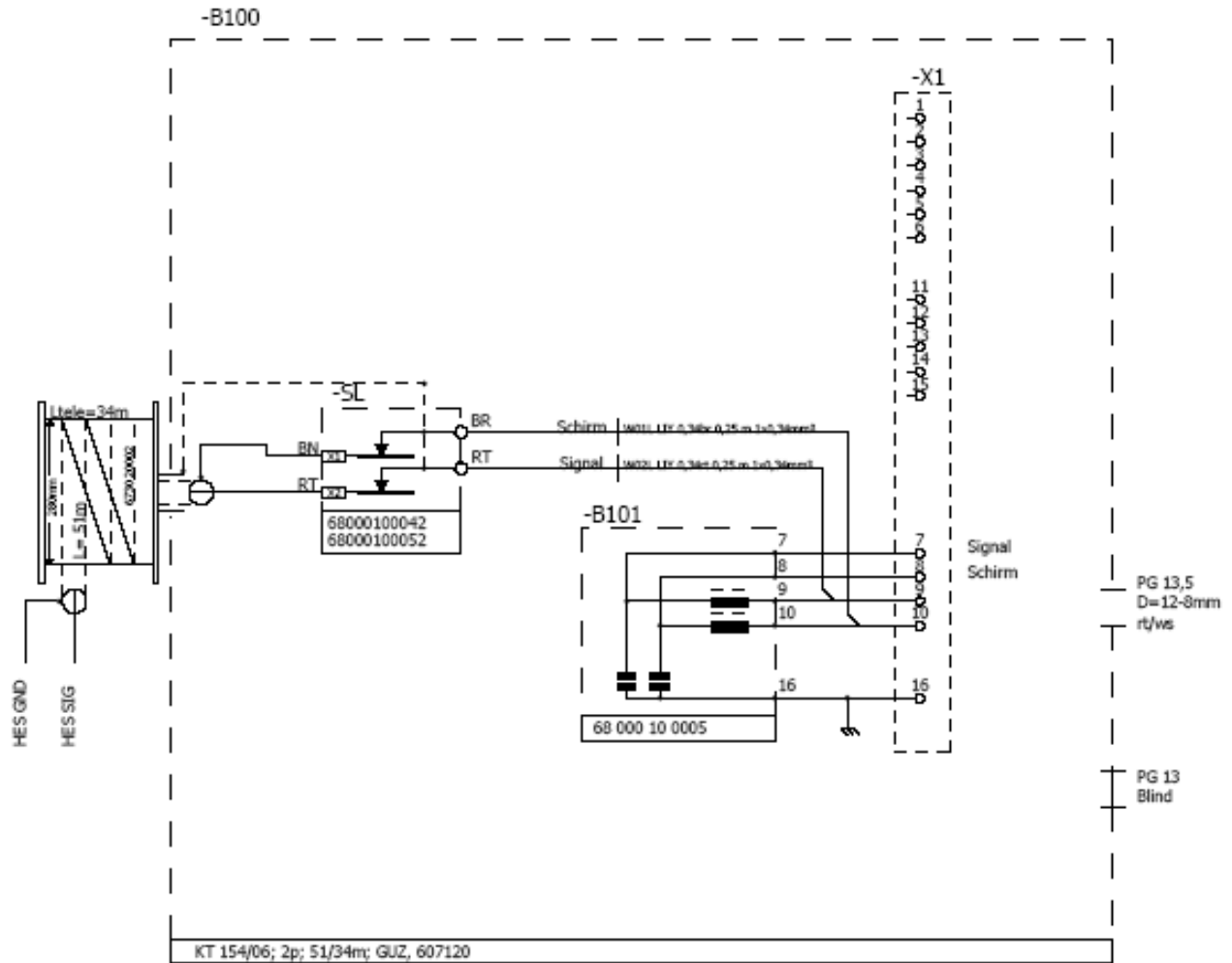

## **5 MOUNTING OF THE REEL, CABLE GUIDES, AND BRACKETS**

After you have determined the best location for mounting the reel, check that the antenna sensor will have a unobstructed straight line between the reel and guides. (it is recommended that the first cable guide be 4-5 feet in front of reel and 4-5 inches below where antenna releases off reel in order to supply proper tension).

The extra antenna sensor **NOT** wound on the reel provides for the distance between reel location and tip when retracted. This can be left loosely wound around reel so that it is out of the way during reel installation.

If needed install additional antenna sensor between fixed section of the reel and the ANTENNA LEAD-IN Cable coming out from control box. Be sure there is enough slack for any possible movement in this area and that the cables are routed out of the way from wear or possible abuse.

Reel and cable guides should be mounted without violating the structural integrity of the equipment. The brackets and hardware furnished with your SIGALARM should be adequate for most installations.

### **The main considerations are:**

- 1. The antenna sensor is kept 2-7 inches off the solid metal boom. (Keep in mind that some boom shielding might occur and sensitivity adjustments may need to be made)**
- 2. The reel, cable guides, and brackets are securely mounted to boom**
- 3. You have crimped the (2) female pins provided on the end of the sensor cable at tip (slide heat shrink connector over antenna prior to inserting these female pins into jumper connector)**
- 4. The antenna sensor end from reel is firmly clamped at the boom tip to the deadman with a V clamp provided prior to the jumper connector**
- 5. The antenna sensor can freely slide through the guides**
- 6. Pigtail Assembly (provided) is installed correctly: Attach angle brackets (supplied) to each side of the tip on the last extension section, use the remaining (2) V clamps, clear hose, and hardware provided to attach antenna pigtail. Run this cable back to the (quick disconnect) jumper connector and attach.**
- 7. You will need to drill out the existing hole in cable reel for our sensor cable. Use silicone once antenna is feed threw this hole to keep water out of reel.**
- 8. Use a properly sized reel for equipment. Do not over tighten the spring or damage may occur.**
- 9. You have extended the boom to check mechanical operation.**
- 10. Prior to operation -Use the hold to test button on the control panel to verify that the entire antenna system is working correctly.**

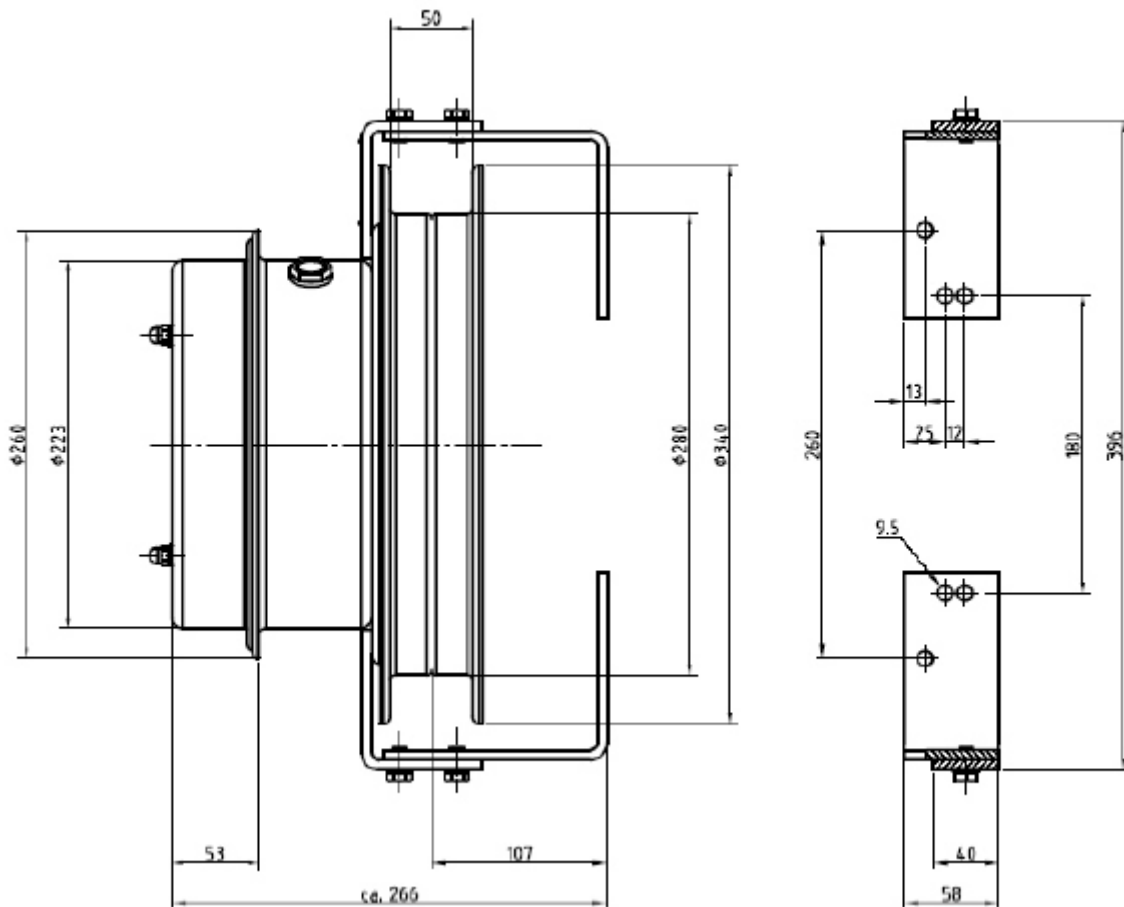
**CABLE REEL DIMENSIONS**

# BOOM INSTALLATION LOCATIONS

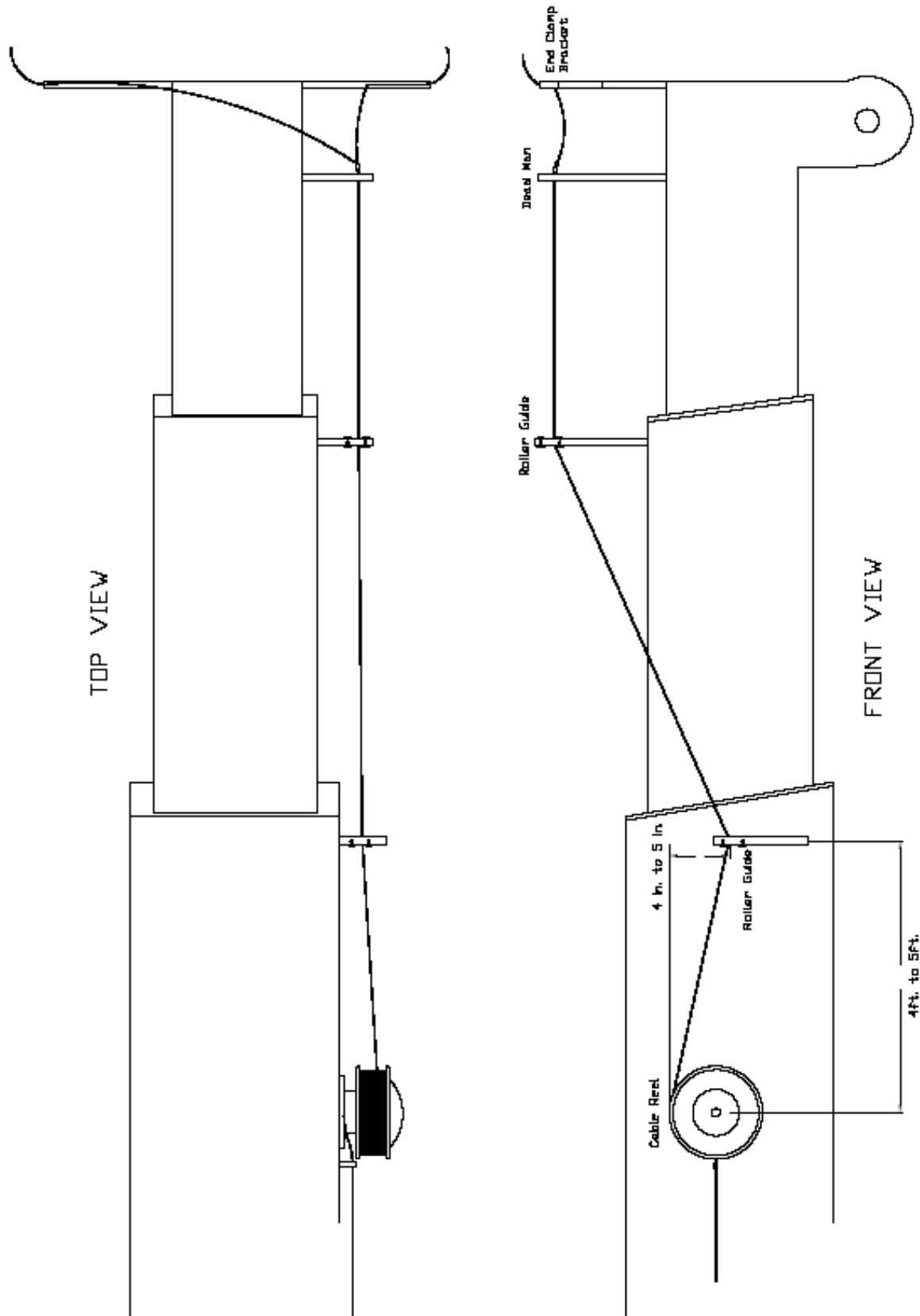

### 6-PIN SCHEMATIC

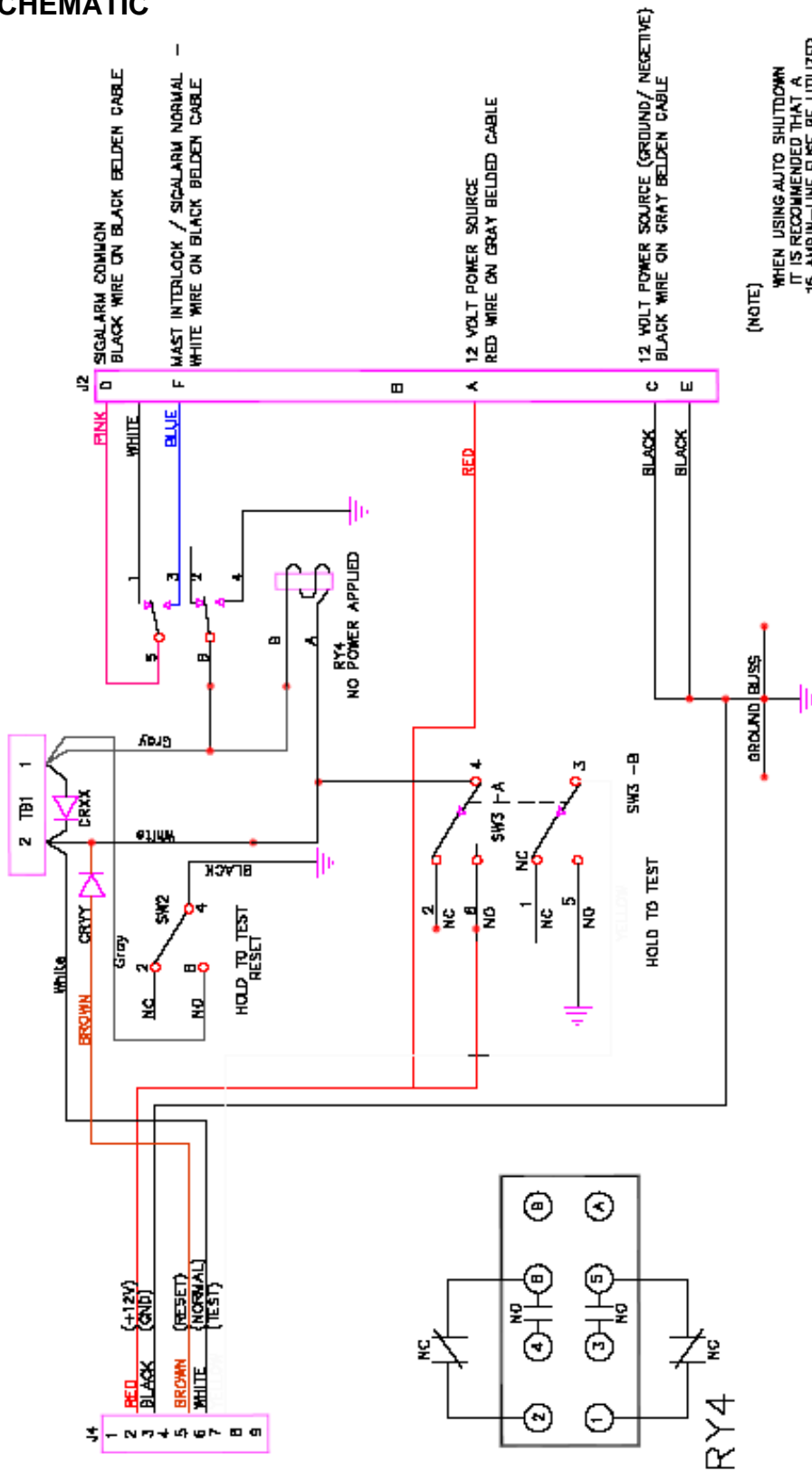

(NOTE)  
 WHEN USING AUTO SHUTDOWN  
 IT IS RECOMMENDED THAT A  
 15 AMP IN-LINE FUSE BE UTILIZED  
 TO PROTECT RELAY RY4  
 FROM BEING DAMAGED THE FUSE  
 CAN BE INSTALLED IN EITHER PIN  
 (F) OR (D)

**SPECIFICATIONS**  
 15 AMP CLOSED CIRCUIT BETWEEN PIN D AND PIN F WHEN THE FOLLOWING REQUIREMENTS ARE SATISFIED  
 A: - 12 VOLTS APPLIED TO SIGALARM  
 B: - NO ALARM/ AFTER SYSTEM HAS BEEN RESET AND THE SENSITIVITY HAS BEEN ADJUSTED

## 6 ANTENNA INSTALLATION

Antenna leads use a minimum of 22 gauge wire. These 2 wires can be run internal or external of the Nycoil. These wires are to be connected to the Multipin Connector at the end of the pigtail. Female pins are included and are to be inserted in holes 1 and 3. Pins 2 and 4 will have a jumper pre inserted.

Power for the SIGALARM should come from a switch that powers up the truck or mast system. This needs to be a constant 12VDC, which is available when the mast is to be raised.

*Note: A ground wire should be mounted to a good vehicle ground at the point of picking up power. The negative terminal of battery used to supply Sigalarm should be grounded to chassis (this measurement should be less than two ohms)*

**SIGALARM control box needs to be grounded by sanding off the exposed mounting hole and connect to a good vehicle ground. Battery and Horn and Auto Shutdown Cable-**Three cables with six pin male connector.

*White cable is for the external horn  
Gray cable is for 12VDC power source. **RED +, BLACK -**  
Black Cable is for the Auto Shutdown Feature.*

**Note:** Reset button must be pushed when auto shutdown feature is used whether power lines are detected or not in order to return internal relay to it's normal closed position.

**Antenna Lead-In** -Single black shielded cable with 2 pin male connector, to be ran to antenna port where the wires tie into the Nycoil. These wires should be soldered and covered with shrink tube. "Note" when cutting to fit insure that the ground wire is long enough to be able to ground to the vehicle

## 7 TESTING

### CIRCUIT AND ANTENNA SENSOR TEST

Push the TEST BUTTON and hold it there: the green light should remain on, the red light will flash, the interior buzzer sound, and the exterior horn(s) sound. This should occur within the first 3 seconds after pushing and holding the test button. If the green light goes off during this time, there is a cut in the antenna, a jumper pin problem, or an internal failure.

## 8 TROUBLESHOOTING TIPS

### APPLY POWER TO SYSTEM

If power LED (green) does not illuminate, check to make sure the battery cable was connected to the battery with the correct polarity.

If green power LED still doesn't illuminate, clean and tighten battery connections and affirm that power is getting to unit. Check that the black wire is connected to negative, and the red wire is connected to positive.

**NOTE:** Verify that the equipment to which the SIGALARM PWS is mounted is negatively grounded.

### GREEN POWER LED

With power available to the system, push and hold reset button. If power LED does not illuminate, but horns alarm, and the red alarm LED is flashing the power LED may be defective or antenna is bad.

(Call Factory 1-800-589-3769)

### INTERNAL HORN

Repeat same steps as above. Check connectors and cable. If still inoperable, check wires to EXT horn for pinching (shorts). If problem remains, call the factory.

### BATTERY CABLES

Check battery posts and the battery cable for damaged and verify that 12VDC is being applied to the control module.

## 9 SPECIAL NOTES

Adjust controls to safe working conditions at each location. It is recommended that you be assisted by a person on the ground to further insure that you do not contact the power line during set-up of SIGALARM.

When mast is raised for extended operation, check sensitivity and readjust if necessary. The longer the mast is the more sensitive the detection sensor.

If the equipment is wired for 110/220VAC night lights which are not completely shielded or grounded, the SIGALARM may be activated in its most sensitive position by the electric field that exists when lights are in operation.

Since atmospheric electrical storms generate a similar field to voltage transmission lines, the SIGALARM may be activated during such storms, depending upon distance and intensity.

When operating in close proximity to high voltage power lines, vehicles should be prohibited from traveling between the crane/boom and power line.

### **SPECIAL NOTES:**

**It is DANGEROUS to operate any "high lift" vehicle beneath high voltage lines that are energized. Confirm their condition with SIGALARM.**

**It is DANGEROUS to operate any equipment directly over high voltage lines. It will be necessary to re-calibrate the unit if you must work above power lines. This is highly recommended against.**

**It is DANGEROUS to operate large equipment in an electrical storm.**

**IT IS RECOMMENDED THAT WHEN MULTIPLE VOLTAGE LINES ARE PRESENT, THAT THE UNIT BE SET TO THE LOWEST VOLTAGE LINES**

## 10 SPECIFICATIONS:

1. Power requirements:
  - a. input voltage--+11to +15VDC
  - b. input current
    - i. Standby-200 ma DC max
    - ii. Operating-4amps DC peak
2. Operating temperature: -29F to +158F
3. Alarm Outputs: The Sigalarm provides alarm outputs in 3 forms simultaneously:
  - a. Visual-by means of a flashing red light mounted on the control module.
    - i. Repetition rate: Proportional to electric field intensity at the sensor cable, up to a maximum of 5 alarms/second
  - b. Audible-internal buzzer
  - c. Audible-external horn
    - i. Repetition rate: Proportional to electric field intensity at the sensor cable, up to a maximum of 5 alarms/second
4. Sensing: Electric field, 60Hz or overseas 50Hz
5. Sensitivity adjustment: Front panel controls provide means for coarse and fine adjustment of the SIGALARM sensitivity. The coarse control adjusts the sensitivity by 1.0,10, 100, 1000, 10,000, and 100,000. The fine control adjusts the sensitivity within each range set by the coarse control, providing a means of continuous adjustment of sensitivity from zero to the maximum sensitivity set by the coarse control.
6. Size 8" X 7.55" X 4"
7. Range of effectiveness: Depending upon the proximity of the overhead high voltage line, and its intensity, SIGALARM can be adjusted to actuate the warning alarm at any desired distance from 10feet (OSHA minimum) to several hundred feet.

## OPERATION

### 11 OPERATIONAL INTRODUCTION

Energized high voltage power lines are a constant and deadly danger to anyone working with or around equipment that can be raised 25 feet or more above the ground. No safety or warning system should be used *in place of* standard safety rules and precautions. No warning device can ABSOLUTELY PREVENT an accident! When properly installed and operated, the SIGALARM system will provide reliable PROXIMITY WARNING.

#### 11.1 GENERAL DESCRIPTION

The SIGALARM PROXIMITY WARNING SYSTEM consists of:

- (1) An antenna sensor- to protect the entire length of the mast and
- (2) A control module-which contains the electronics to detect the electrostatic field surrounding all power lines, determine the field strength and control the distance at which visual and audible alarms will be activated.

This is a WARNING system and should **not** be used as a MEASURING device. It is designed to give reliable and repeatable warning of the presence of dangerous high voltage in the immediate vicinity as well as allowing the operator to set an **APPROXIMATE** safe "working" distance away from power lines.

Operation is simple and requires no special knowledge of electronics, power line theory or electrical fields.

#### 11.2 THEORY OF OPERATION

Your SIGALARM proximity warning system is a reliable and finely tuned "radio" designed to receive only one selective and potentially life-threatening program – the detectible field present around all high voltage transmission (power) lines. Unlike your radio, which may pick up unwanted stations and/or static, your SIGALARM will only receive 60Hz. The unit can also be adjusted to alarm at 50Hz for countries having 50Hz power lines.

The strength of the signal (field) depends on the voltage and the distance from the lines. Simple adjustment of COARSE and FINE controls on the SIGALARM unit permit accurate and repeatable settings at which an operator would like a warning. After the original desired setting is made, a visual and audible alarm will occur whenever the "**danger zone**" is approached.

## 12 FRONT PANEL FAMILIARITY:

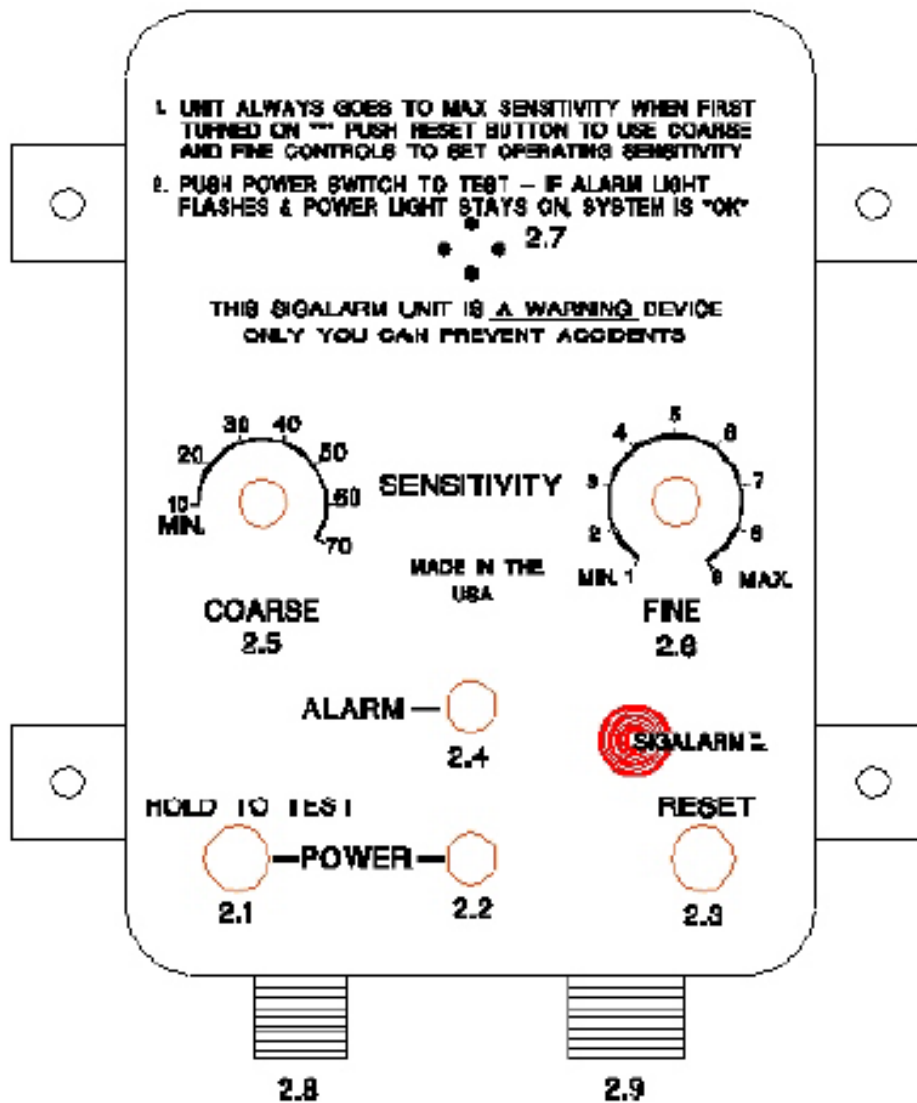

- 2.1 Hold to Test Push Button
- 2.2 Power Light and System Condition Indicator
- 2.3 Sensitivity Reset Button
- 2.4 Red Alarm Light
- 2.5 Coarse Control
- 2.6 Fine Control
- 2.7 Internal Horn
- 2.8 Antenna Sensor Cable Input Jack
- 2.9 Power Input / External Horn Cable & Auto Shutdown Output

## IDENTIFICATION AND DESCRIPTION

- 2.1 **Hold To Test Push Button** - Allows the operator to push and hold this button. This button then checks the entire system, if the green power light stays on, external horn sounds, Internal buzzer works, and red light flashes the system is fully functional.
- 2.2 **The GREEN POWER** - light indicates power is on when power is applied. The green power light indicates condition of antenna, when the Hold To Test button is activated. If the green power light stays on this indicated that the antenna is OK. If the green power light does not stay on that indicates that there is an open circuit in the antenna.
- 2.3 **Reset Button** - allows you to take unit off max sensitivity and use the coarse and fine controls to adjust sensitivity. Push and release the reset button to take unit off maximum sensitivity. The unit is now at its last setting. The coarse and fine controls can be used to adjust sensitivity up or down as needed.
- Each time the Power is turned off and on, the control module will automatically be at maximum sensitivity. You will need to press the reset button each time Power is turned off so that you can adjust the sensitivity by using the coarse and fine knobs.
- 2.4 **The RED ALARM LIGHT** - flashes when the danger zone has been approached, or when the hold to test/reset button has been pushed (Interior and exterior horns are activated simultaneously.)
- 2.5 **COARSE CONTROL** - changes sensitivity/response to field strength/signal by a factor of 10 times per step.
- 2.6 **FINE CONTROL** - changes sensitivity/response to field strength/signal by 1 time per step - numbers 1 through 9. Fine is used to set sensitivity more precisely.
- 2.7 **INTERNAL HORN** - Audible sound at same time as RED ALARM light and external horn.
- 2.8 **ANTENNA SENSOR CABLE INPUT CABLE.**
- 2.9 **BATTERY CABLE INPUT, AUTO SHUTDOWN CABLE, and EXTERNAL HORN.**  
Internal relay is opened at same time internal alarm light and horn are energized in addition too providing 12 volts for auxiliary lights and/or horns. Maximum output, 4 amps. Relay stays open until reset button is pushed.

## 13 OPERATING PROCEDURES:

### A “High Voltage Proximity Warning Device” -ON TELESCOPING BOOMS

**“High Voltage Power”** *means any electrical line or lines installed above ground level having a voltage in excess of 750 volts between conductors or from any conductor to ground.*

#### 13.1 OPERATION

1.) Once power (12VDC) is applied to the control module, the unit will go to max sensitivity. If power lines are in the vicinity of the vehicle (+250 Feet of 12,500 v line) an alarm will sound.

Note/Option: When the auto shutdown feature is used the normally closed relay opens whether or not an alarm sounds.

2.) The operator must insure that there are no overhead power lines above the vehicle. After a complete check above, the boom can be raised by pushing the reset button (closing relay) and adjusting the sensitivity coarse and fine knobs. (See note 2).

You the operator are in control of every job site, it is up to you to insure that there are no overhead power lines above your vehicle.

When adjusting the Sigalarm for operation near a power line, the alarm set point should be far enough away from the line to give you time to react. Unit should be set to give a warning prior than the OSHA minimum for that line. Never approach any power line closer than OSHA minimum.

**Note 2:**

After an initial alarm and pushing the reset button, the Sigalarm unit will be set at its last working position. (**Warning: this may NOT be right for this job site**). If the alarm is still sounding after resetting, make sure no power lines are overhead, then reduce the sensitivity and raise the boom. You adjust the control knobs up or down to increase and decrease sensitivity and locate the alarm set point. After an alarm: Always leave the coarse setting at its maximum sensitivity position possible. Reduce the sensitivity by using the following method:

Adjust the fine control knob counter clock wise to silence the alarm. If, the alarm is still activated after turning the fine control all the way left (1 is the least sensitive setting on the fine knob), adjust the coarse control left one position and repeat the fine knob counter rotation from maximum 10- until the alarm stops. Once the alarm stops, the reset button must be pushed and held for approximately 2-3 seconds. This allows the boom to be raised if using auto shutdown feature. If in the process of raising the boom the alarm re-activates you must decrease the sensitivity again, and re-push the reset button. This will allow the operator to continue to raise the boom.

Once the boom is in the desired position the coarse and fine control knobs should be adjusted to the maximum sensitivity position without alarming. The system is now active and will help protect you and the vehicle from a power line contact.

**Warning: Never just turn the controls knobs all the way down to the left (least sensitive positions). This could endanger yourself and fellow workers.**

**Warning: Sigalarm must be calibrated at each location.**

A common practice that should be used when operating the SIGALARM High Voltage Proximity Warning Device is to do a system test at the beginning and end of each operating day. Push and hold the test button, while holding this button observe that the green power light stays on, red light flashes, the interior buzzer sounds, and the exterior horn(s) sound. This verifies that both the electronics and the antenna are working properly.

Sigalarm is not intended to be a replacement for safe work habits, training, observation of state and federal laws and common sense. **Never operate closer than federal and state laws allow.** Remember local regulations may be more stringent than federal laws. Sigalarm is a tool to AID YOU.

Please follow the above directions carefully; they could save yours and your fellow workers lives one day.

\*\*\*If a knob shield is being used to cover the sensitivity controls the operator cannot adjust sensitivity up or down. The operator must move further away from the power lines to raise the boom if the auto shutdown feature is used and an alarm sounds after initial alarm and pushing the reset button.

## 14 COMMON QUESTIONS CONCERNING VOLTAGE/GROUNDING:

### Prior to installation of Sigalarm:

Sigalarm detects the electrostatic field and it is important that the entire chaise be grounded to the negative terminal of the battery. The following checks should be made to avoid problems:

- 1- Measure the ohm value of the ground cable used to ground the negative terminal of the battery to the chaise. The cable should be less than one ohm.
- 2- Measure the ohm value from the negative terminal of the battery to chaise. This measurement should be made near the battery. This reading should be approximately the same ohm value of the cable above.

The power supply to Sigalarm must be plus 11 to plus 15 volts DC. (Note) the voltage that is supplied to Sigalarm should be verified by measuring the plus supply voltage to the chaise of the vehicle. If the voltage is less than the battery that supplies the voltage then the battery to negative terminal to chaise should be checked.

### Horn (quacks)

- (A) Insure the red wire in the white cable from Sigalarm is attached to the red wire (horn)
- (B) Insure that the black wire in the white cable from Sigalarm is attached to the white wire (horn)
- (C) Insure that the Sigalarm control box is grounded to the chaise (Above)
- (D) Insure that the chaise is grounded to the negative terminal of the battery
- (E) If the system does not function properly after completing (A),(B),(C), and (D) remove the black wire from white cable and hook up a test wire from the black cable on (horn) to the negative terminal on the battery

Note: If the system functions properly when the test wire is connected it indicates that the chaise and Sigalarm are not properly connected to the battery negative terminal of the battery used for supply power.

Notes: A relay from Sigalarm to the horn should also solve problem, unless there is a low voltage supply problem.

**Voltage:**

Low voltage supply might be affecting the operation of the horn. (short term signal drop).

Try lengthening the cable to the horn - The longer the wire is to the horn the more inductance (less of a leap to end of wire) which does not allow the horn to draw as much current. (6volt minimum to horn)

The shorter the wire is to the horn the more likely it is to cause a problem on a vehicle that has a marginal power supply 4 amp max draw while Sigalarm is alarming.

Check power supply that feeds Sigalarm under full load find out if and how it is shared.





[www.skyazul.com](http://www.skyazul.com)

**SkyAzul, Inc.**

200 W. Main Street, Suite, 2A  
Middleton, MD 21769  
Phone 301-371-6126  
Fax 301-371-0029  
[info@skyazul.com](mailto:info@skyazul.com)

